



T1/E1 Fiber Service Unit



The RFL T1/E1 Fiber Service Unit (FSU) offers economical fiber extensions for the IMUX 2000/4000 family of products along with ability to add fiber connectivity to other manufacturers Multiplexers.

Key Benefits / Features

- **Low cost fiber solution for T1/E1 fiber extension or point to point long haul applications**
- **T1 or E1 all in the same package.**
- **Wide range of LED and LASER optics for multi-mode and singlemode with distances up to 90Km (55.9 miles)**
- **Wide range power supply (38-150Vdc)**
- **Rugged, easy to mount enclosure for flexibility of installation.**
- **Designed for harsh environments such as substations or road side equipment sheds.**

The RFL T1/E1 Fiber Service Unit (FSU) is a DC powered, environmentally hardened T1/E1 Fiber Service Unit that can be electrically interfaced to a SONET or SDH multiplexer to extend via fiber the communication signal to a IMUX 2000 T1 or E1 multiplexer. Additionally, by using two of the FSUs end to end, this product can provide an interface between any T1 or E1 multiplexer with compliant electrical T1 or E1 interface.

The RFL T1/E1 FSU is easy to setup and configure and offers switch selectable T1(ANSI T1.104) or E1 (ITU G.703/704) operation. Line coding is also switch selectable for T1 (AMI or B8Zs) and E1 (AMI or HDB3). The fiber optic modules utilize an efficient and economical Code Mark Inversion (CMI) light modulation scheme .

For commissioning and maintenance the RFL T1/E1 FSU supports digital and optical loopbacks along with internal or loop timing modes. The unit also has the ability to transmit "All Ones" pattern and offers a Variable Line Build Out (LBO) to make the unit easy to apply and monitor.

The front interface panel (Figure 1) offers a DB-15 connector for the T1 and E1 (120 Ohm) interface. BNC coax connectors are provided for the E1 75 Ohm connections. The RFL T1/E1 FSU can be configured with 1300nm multimode or single mode LED emitters or 1300 and 1550 LASER single mode emitters. Depending on the fiber emitters used, T1 or E1 signals can be transmitted up to a maximum of 90 Km (55.9 miles) based on typical loss calculations. All fiber options feature automatic gain adjust so receiver cannot be saturated, meaning no attenuators are required.



Electrical & Environmental

Operating Temperature	-20 °C to +55 °C
Operating Humidity	90% RH Non-Condensing @ 40 °C
Supply Voltage	38-150Vdc
Power Consumption	Less than 5W
ESD Withstand	ANSI C.37.90.3
RFI Withstand	ANSI C.37.90.2
SWC Withstand	ANSI C.37.90.1
Dielectric Withstand	2500 VDC (Power and Alarm Inputs)

Regulatory requirements

MTBF	>1,000,000 Hours
Bellcore TR332 Issue 5, Method 1 Case 3, Temp = 25 C	

Alarms

Alarm Relay Output Form	"C" (SPDT)
Alarm Relay Open Circuit Voltage	300 VDC
Alarm Relay Current (Continuous)	1 Amp
Alarm Relay Breaking Current	1 Amp, Non-inductive

Fiber Optic Interface Specifications and FSU

Ordering Part Numbers:

SOURCE	WAVELENGTH	FIBER	SYSTEM GAIN	TYPICAL DISTANCE*
LED #107600-300	1300 nm	MM	25 db	19.5 Km / 12.1 Miles
LED #107600-200	1300 nm	SM	19 db	26.6 Km / 16.5 miles
LASER #107600-400	1300 nm	SM	36 db	58.9 Km / 36.6 miles
LASER #107600-500	1550 nm	SM	30 db	90 Km / 55.9 miles

* - The stated "Typical Distances" are based on the following assumptions:

- 0.05 db splice loss every 2 Km.
- 2 db Connector loss for ST connector (total both ends).
- 1 db/Km loss for 1300 nm Multimode fiber.
- 0.5 db/Km loss for 1300 nm Singlemode fiber.
- 0.25 db/km loss for 1550 nm Singlemode fiber.

T1 Interface

Electrical Specification	ANSI T1.104
Frame Format	ANSI T1.104
Line Coding	AMI/B8ZS (Jumper/Switch selectable)
Signaling	Transparent to product
Interface Impedance	120 Ohm Twisted pair
Connector	D-Subminiature 15 position male connector
Multiframe Format	ESF or SF

E1 Interface

Electrical Specification	ITU G.703
Frame Format	ITU G.704
Line Coding	AMI/HDB3 (Jumper/Switch selectable)
Interface Impedance	120 Ohm Twisted Pair or 75 Ohm Coax (selectable)
Connector	D-Subminiature 15 position male connector and 2 BNC coax connectors.

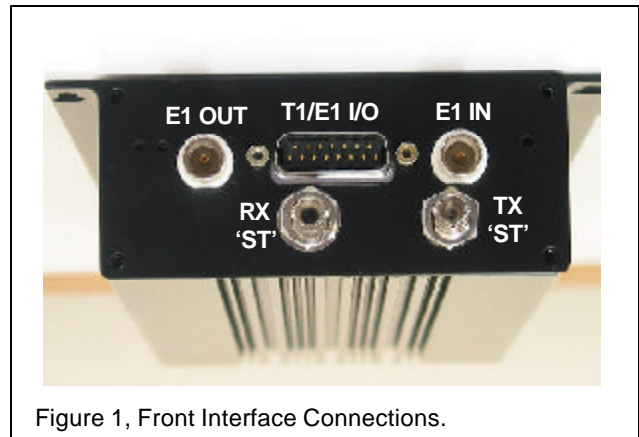

Figure 1, Front Interface Connections.



RFL Electronics Inc
 353 Powerville Road
 Boonton TWP, NJ
 07005 - 1951
 www.rflect.com
 sales@rflect.com
 973 - 334 - 3100